

**MAIT**

*recoline*  
**EC 35**

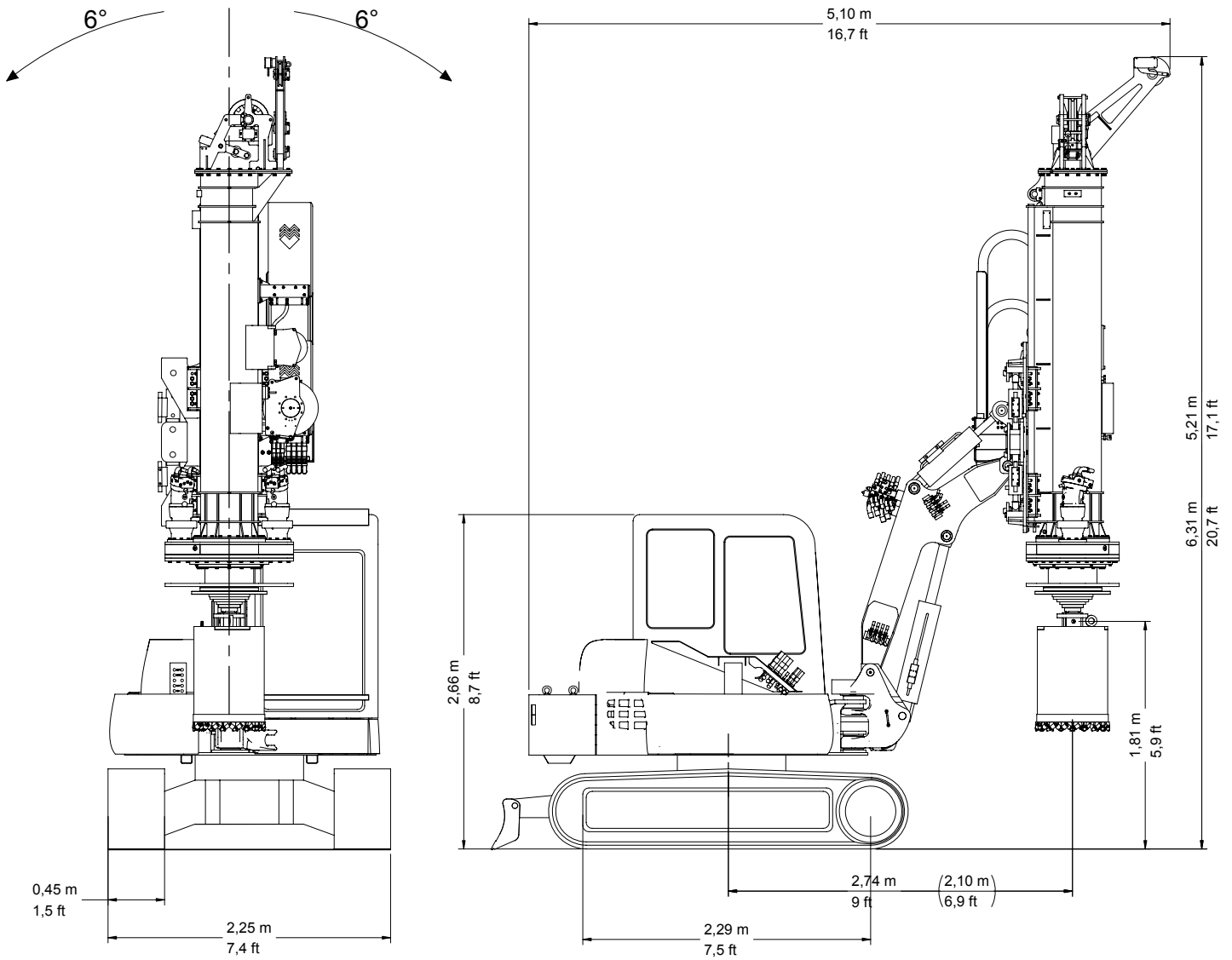



The Ecoline 35 is a specially designed drilling rig for limited access and low head room job sites.

Its moderate size allows easy transportation and use on the job site, and no special transport arrangements are required.

The rig is mounted on a Komatsu base carrier type PC 80. The powerful excavator provides the required flow and pressure to the drill, granting the high torque capability performed by MAIT's power-head.

### TECHNICAL DATA

Excavator base		KOMATSU PC 80
Engine power	45,5 kw	61.5 HP
<b>Rotary</b>		
Nominal torque	30 KNm	22,110 lbsft
Speed	10 - 45 rpm	
Max pullback	27 KN	6,075 lbs
Max pulldown	25 KN	5,625 lbs
Rotary vertical stroke	1.100 mm	3.61 ft
<b>Winches</b>		
1° winch - Max nominal pullback	38 KN	8,550 lbs
2° winch - Max nominal pullback	14 KN	3,150 lbs
<b>Crawler</b>		
Length	2.860 mm	9.4 ft
Width	2.250 mm	7.4 ft
Shoes	450 mm	1.5 ft
<b>Total weight</b>	14 t	30,856 lbs

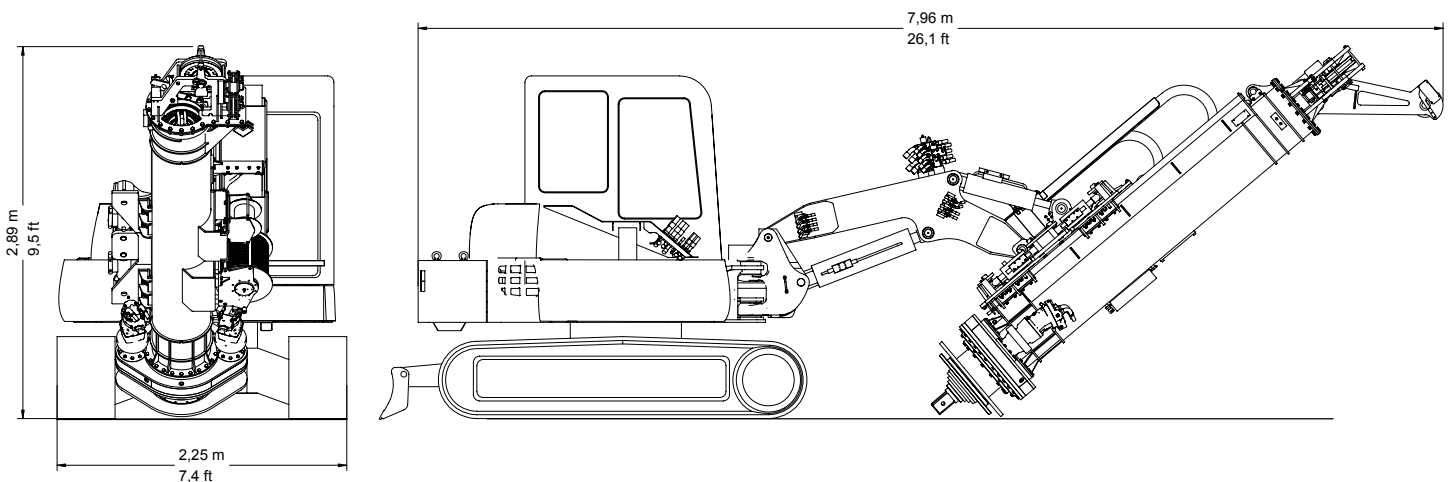

### WORKING CHARACTERISTICS

#### Working with Auger and Bucket

Max diameter	900 mm	3 ft
Max depth	16 m	52.5 ft

The rig is connected to the base carrier through an innovatively designed articulated boom featuring side swinging, adjustable working radius and clearance for 1500 mm (5 ft) diam. pile (special drilling tool required).

This new and creative compact drill concept, allows raked drilling and side drilling with the drill rig.



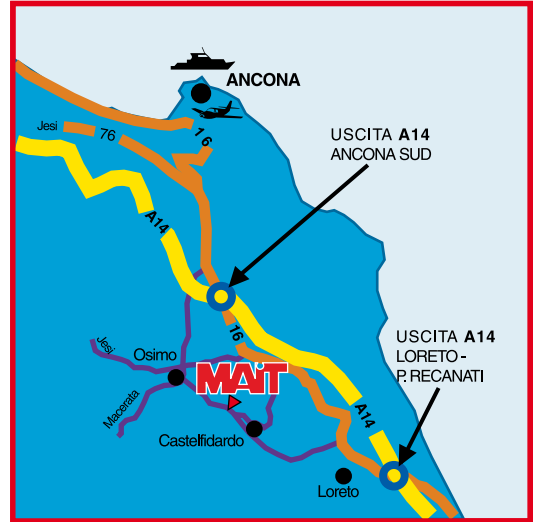

## MAIT also manufactures:

- Hydraulic drilling rigs of every size:
  - for piling, diaphragm walls, continuous flight augers;
  - for water wells;
  - for soil investigation, consolidation, civil engineering;
  - jet-grouting;
- Casing oscillator;
- Power pack;
- Casing tubes;
- Augers and buckets;
- Hydraulic grabs for diaphragm walls;
- Continuous flight auger;
- Tremie pipes;
- Drilling tools and accessories;

## MAIT produit également:

- Des équipements de forage pour:
  - palification, parois moulées, tarière continue;
  - recherche de nappes d'eau;
  - géologie, consolidations, génie civil;
  - jet-grouting;
- Louvoyeuses;
- Power pack;
- Tubes de chemisage;
- Tarières et buckets;
- Bennes pour parois moulées;
- Tarières continues;
- Tubes jet;
- Dents et piquets pour outils;



**MAIT** S.p.A. DRILLING RIGS

Via Flaminia Seconda n° 149/153

P.O. Box 1040 – 60027 OSIMO (AN) ITALY

Tel.: +39 071 7822186 – Fax: +39 071 780535

Web: <http://www.mait.it> – e-mail: [info@mait.it](mailto:info@mait.it)